

SCE275 Service Parts

This is the service parts list for the SCE275. This product was manufactured in both 60 Hz and 50 Hz models. The model number is different for each voltage. 60 Hz are designated with a -1 or -32 at the end, for example: SCE275A-1A or SCE275A-32G. 50 Hz models use a -6 at the end, such as SCE275A-6A.

Electrical parts that belong to the different voltages are described as 115/60, 208-230/60 or 50 Hz.

Changes between the A and D series relate to the compressor's starting components.

The E series changes were to the electrical system of the 50 Hz model.

The F series water cooled models began the use of a different water cooled condenser.

The G series moved the controller to the left side of the chassis.

Table of Contents

Cabinet	Page 2
Air Cooled	Page 3
Water Cooled	Page 4
Refrigeration Components	Page 5
Water System	Page 6
Compressor, Controller, Water Valve	Page 7
Electrical Box	Page 8
Wire Harnesses	Page 9
Wiring Diagram, A series	Page 10
Schematic Diagram	Page 11
60 Hz Wiring Diagram: D, E, F and G Series	Page 12
50 Hz Wiring Diagram: - 6E, -6F, and -6G	Page 13



PLATON SERVICE
8 (800) 500-34-47
www.platonservice.com

SCE275 Service Parts

Cabinet

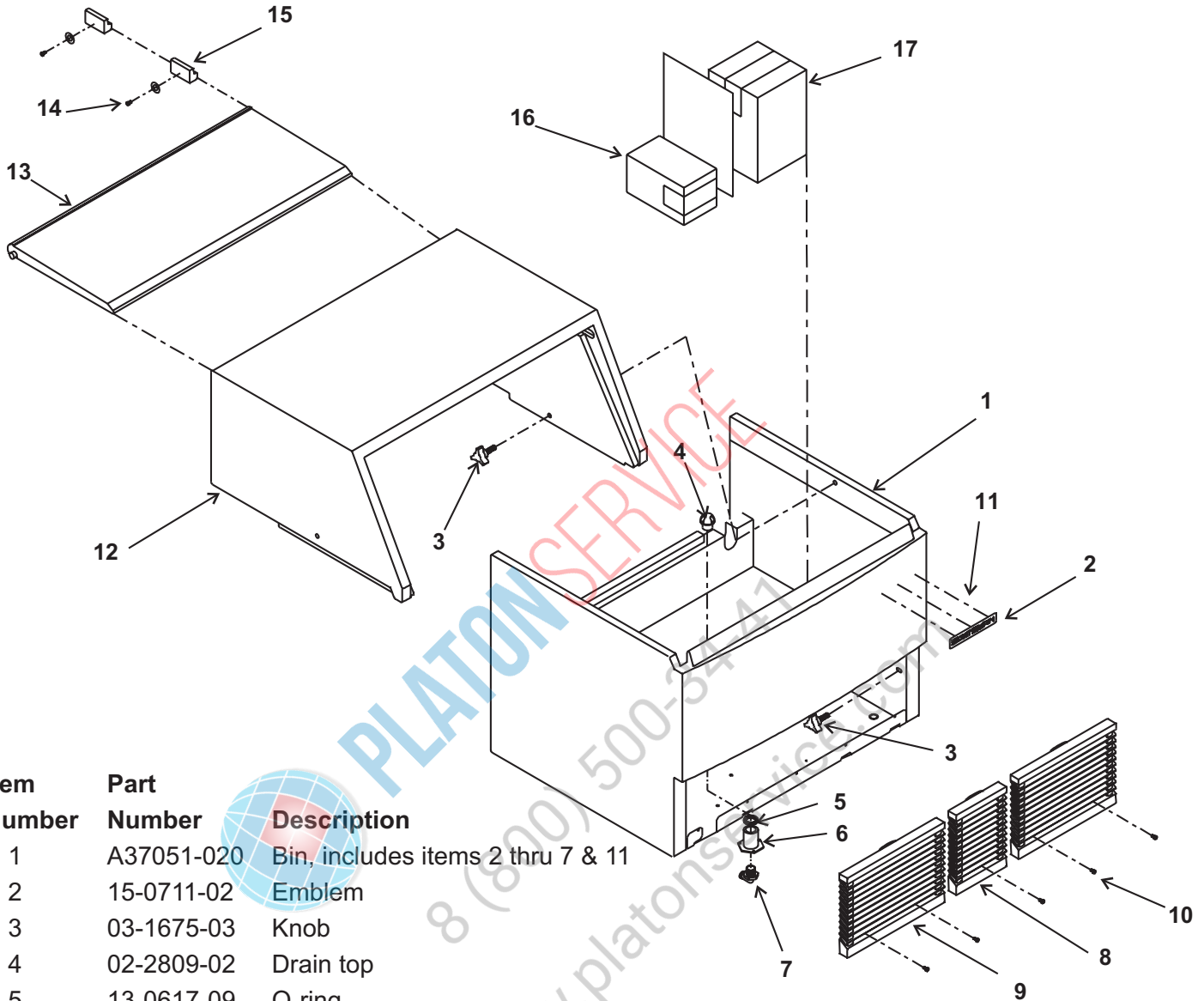

Item Number	Part Number	Description
1	A37051-020	Bin, includes items 2 thru 7 & 11
2	15-0711-02	Emblem
3	03-1675-03	Knob
4	02-2809-02	Drain top
5	13-0617-09	O-ring
6	02-3108-01	Drain fitting
7	16-0822-01	Elbow
8	02-3458-01	Center grill
9	02-3153-01	Grill
10	03-1638-03	Screw
11	03-1562-01	Speed clip
12	A37050-021	Hood, includes items 3, 14, and 15
13	02-3439-01	Door
14	03-1419-22	Screw
15	19-0629-02	Door stop
16	KLP2	Leg kit
17	02-3253-01	Scoop

SCE275 Service Parts

Air Cooled

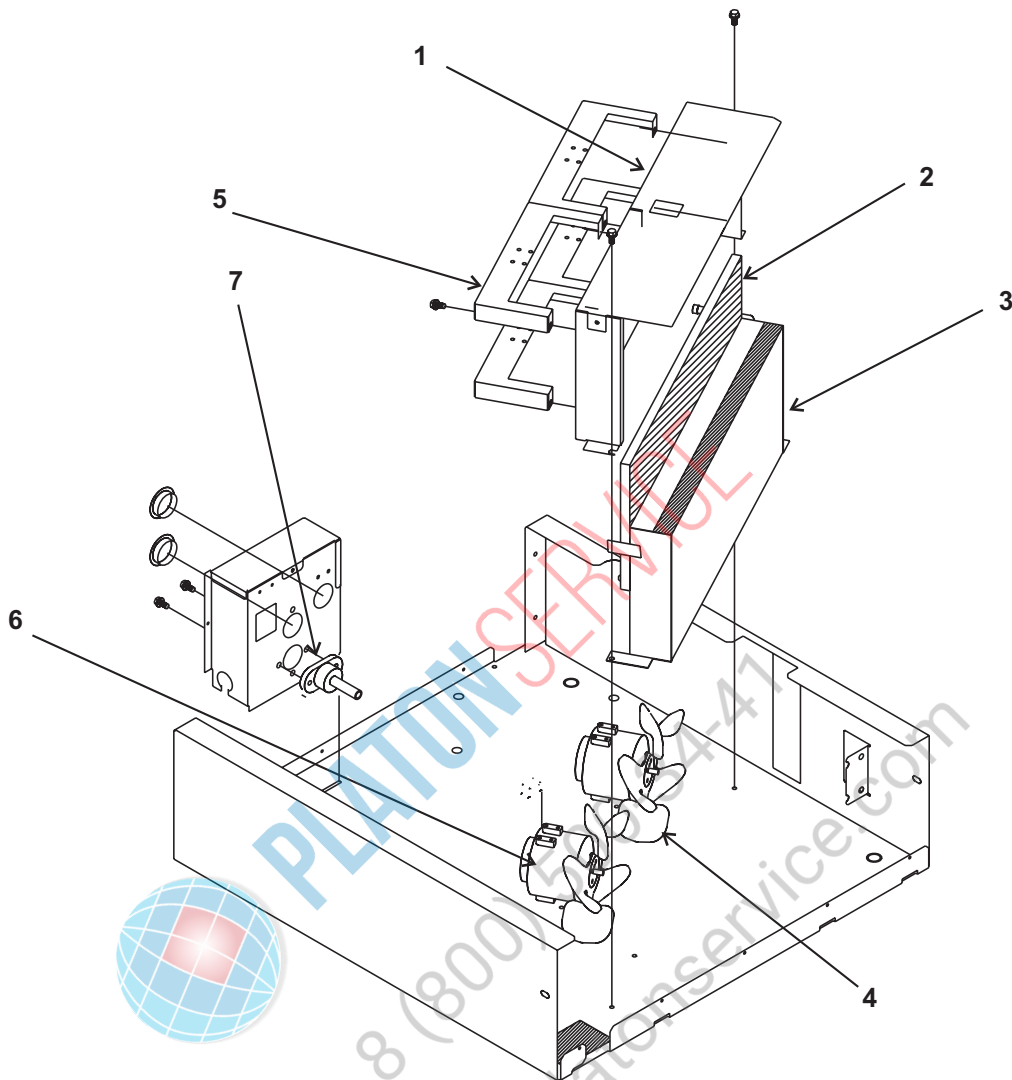

Item Number	Part Number	Description
1	A36742-001	Fan shroud
2	02-3193-01	Air filter
3	18-8782-01	Condenser
4	18-8773-01	Fan blade
5	A37320-001	Fan motor bracket
6	12-1681-03	Fan motor, 115/60 Hz
	12-1681-04	Fan motor, 50 Hz
	12-1681-04	Fan motor, 208-230/60
7	A31828-004	Drain fitting

SCE275 Service Parts

Water Cooled

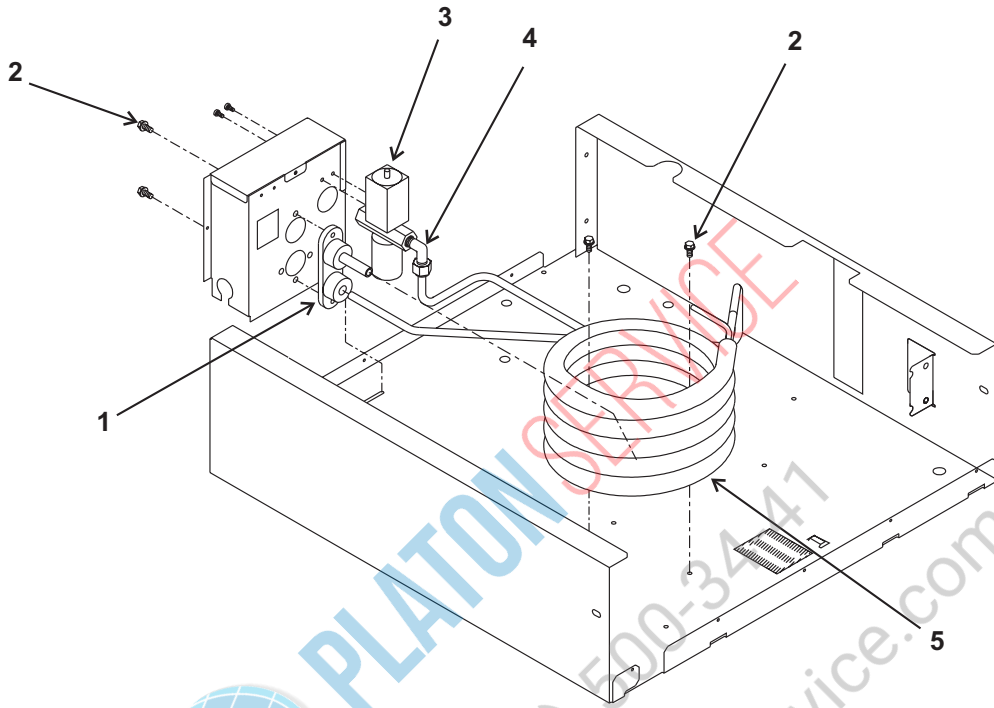

Item Number	Part Number	Description
1	A31878-001	Drain fitting
2	03-1645-02	Screw
3	11-0478-21	Water regulating valve
4	16-0401-00	Elbow
5	18-8803-21	A - E series water cooled condenser
	18-8871-21	F & higher series water cooled condenser

SCE275 Service Parts

Refrigeration Components

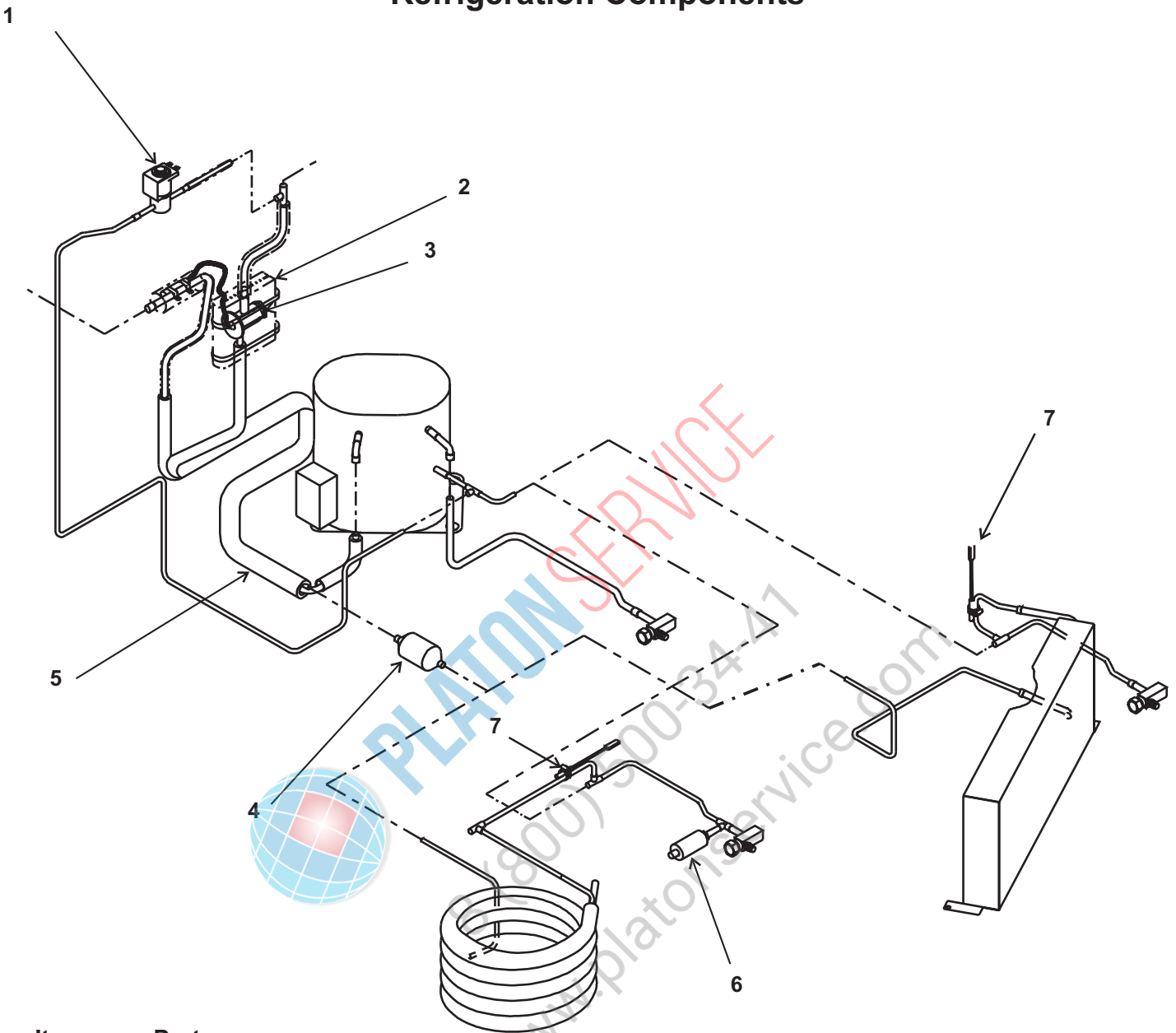

Item Number	Part Number	Description
1	12-2471-21	Hot gas valve w/coil
	12-2719-23	Coil for hot gas valve
2	19-0599-04	Insulation, order 2 units
3	16-1009-22	TXV
4	02-3319-01	Drier
5	A36637-001	Suction line
6	11-0501-21	Hi pressure cut out (WC)
7	12-2556-21	Thermistor

SCE275 Service Parts

Water System

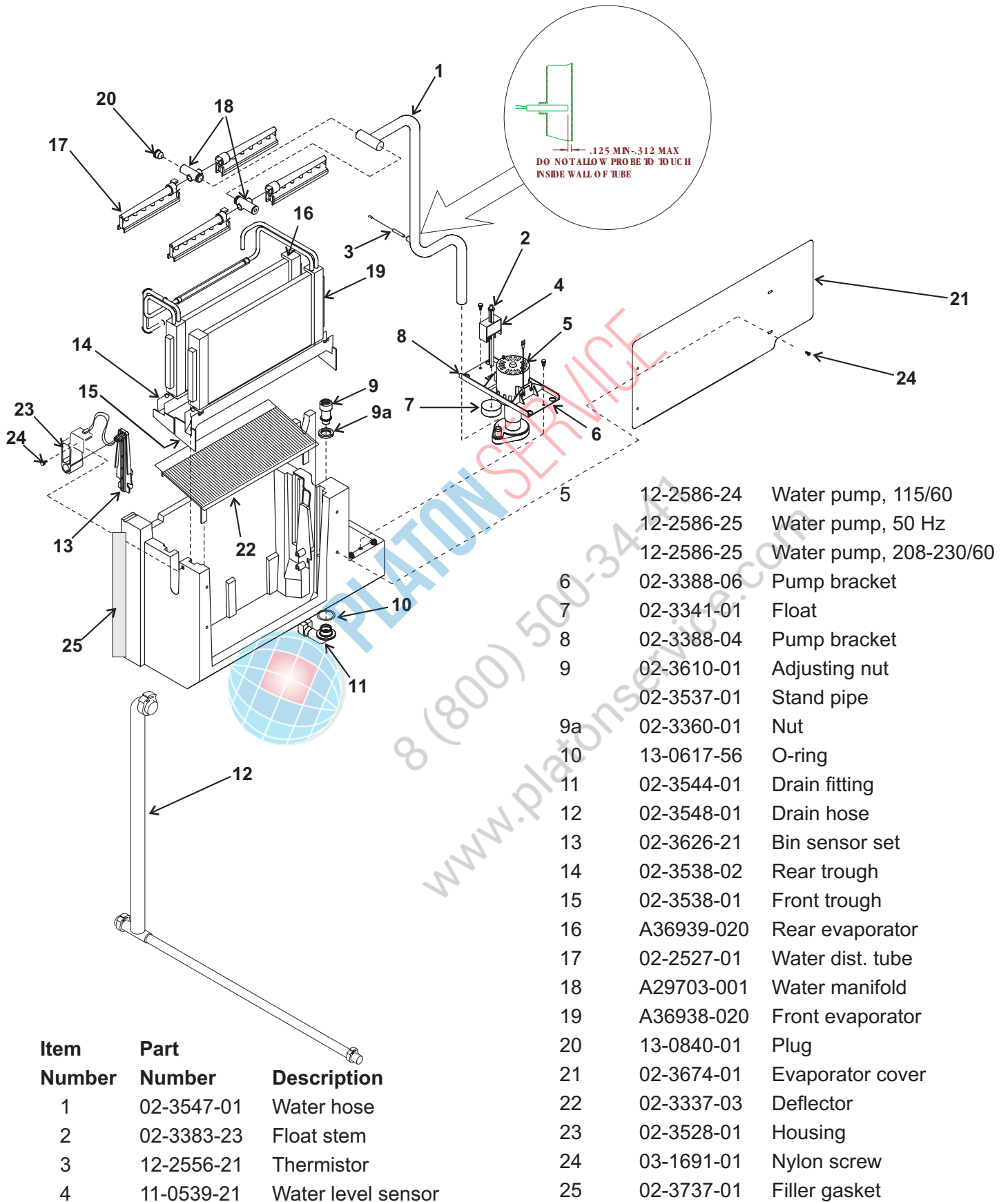

Item Number	Part Number	Description
1	02-3547-01	Water hose
2	02-3383-23	Float stem
3	12-2556-21	Thermistor
4	11-0539-21	Water level sensor

5	12-2586-24	Water pump, 115/60
	12-2586-25	Water pump, 50 Hz
	12-2586-25	Water pump, 208-230/60
6	02-3388-06	Pump bracket
7	02-3341-01	Float
8	02-3388-04	Pump bracket
9	02-3610-01	Adjusting nut
	02-3537-01	Stand pipe
9a	02-3360-01	Nut
10	13-0617-56	O-ring
11	02-3544-01	Drain fitting
12	02-3548-01	Drain hose
13	02-3626-21	Bin sensor set
14	02-3538-02	Rear trough
15	02-3538-01	Front trough
16	A36939-020	Rear evaporator
17	02-2527-01	Water dist. tube
18	A29703-001	Water manifold
19	A36938-020	Front evaporator
20	13-0840-01	Plug
21	02-3674-01	Evaporator cover
22	02-3337-03	Deflector
23	02-3528-01	Housing
24	03-1691-01	Nylon screw
25	02-3737-01	Filler gasket

SCE275 Service Parts

Compressor, Controller, Water Valve

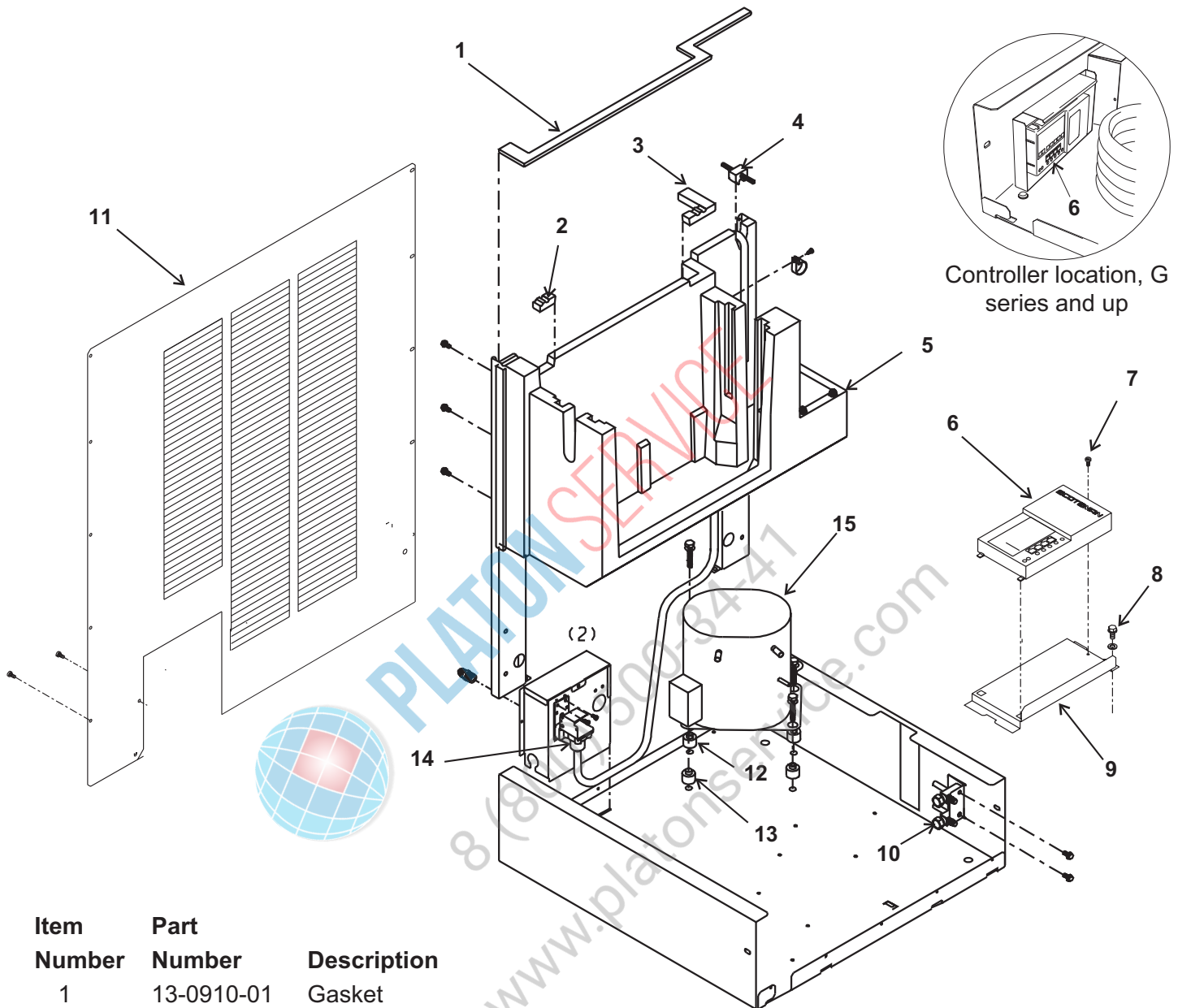

Controller location, G series and up

Item Number	Part Number	Description
1	13-0910-01	Gasket
2	13-0911-01	Tube seal
3	13-0912-01	Tube seal
4	13-0913-01	Water inlet tube seal
5	A36784-001	Evaporator housing
6	12-2838-22	Controller
7	03-1638-03	Screw
8	03-1645-02	Screw
9	A36657-001	Bracket
10	16-0832-21	Service valve
10a	16-0832-03	Port cap
10b	16-0832-02	Stem cap
11	A36608-001	Back panel
12	03-1677-01	Screw - inserts from below
	03-1406-01	Hex nut
	03-1407-01	Washer
13	18-0108-41	Mounting sleeve
	18-2300-27	Grommet
14	12-2548-01	Inlet water valve
15	18-8774-21	Compressor, 115/60
	18-8774-23	Overload for 115/60
	18-8774-26	Compressor, 230/50/1
	18-8774-27	Overload for 50 Hz
	18-8774-22	Compressor 208-230/60
	18-8774-28	Overload for 208-230/60

SCE275 Service Parts

Electrical Box

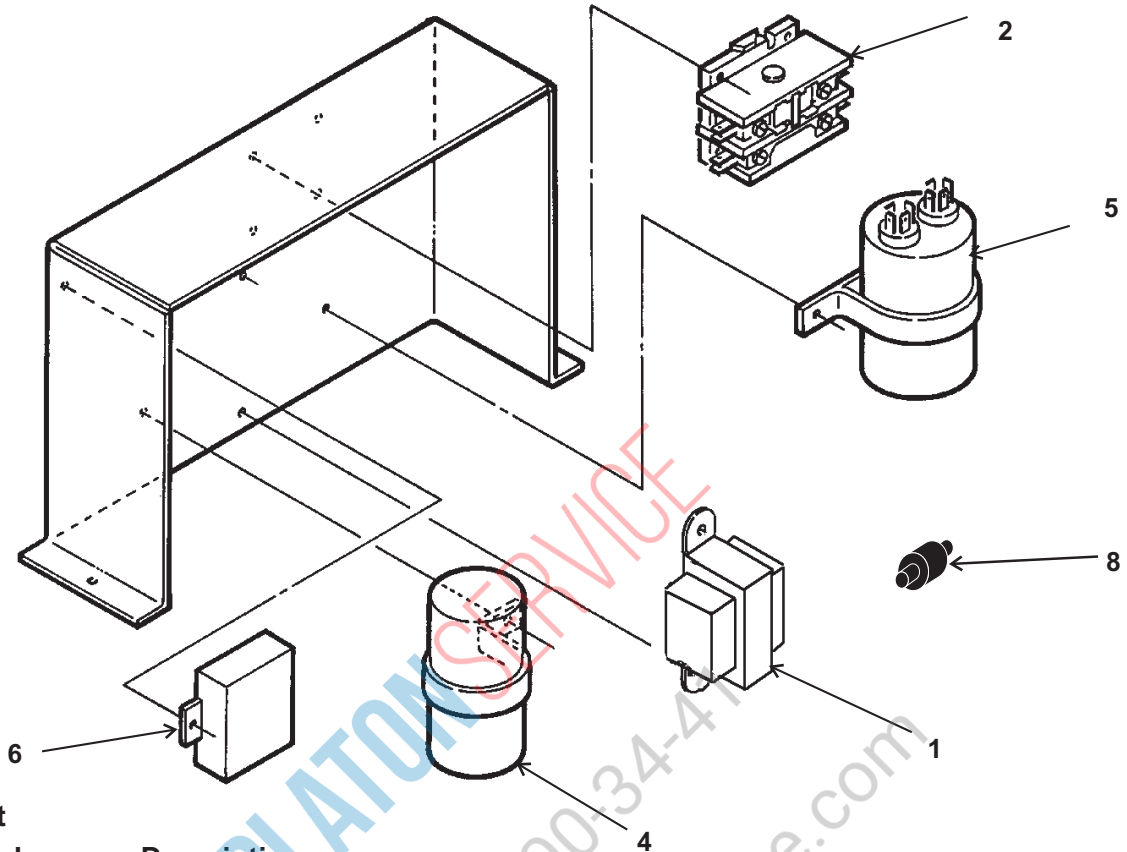

Item Number	Part Number	Description
1	12-2836-01	Transformer, 115/60
	12-2836-02	Transformer, 230/60 or 50 Hz
2.	12-2469-01	Contactor
3	12-2563-01	Control box harness
4	18-1901-55	Start capacitor, 115/60 Hz
	18-1901-56	Start capacitor, 50 Hz
5	18-1902-45	Run capacitor, 115/60 Hz
	18-1902-52	Run capacitor, 50 Hz
	18-1902-52	Run capacitor 208-230/60
6	18-1903-52	Potential Relay, 115/60 Hz
	18-1903-53	Potential Relay, 50 Hz
7	12-1638-14	Power cord, 115/60 Hz
	12-1638-18	Power cord, 208-230 60 or 50 Hz
8.	18-8835-01	PTCR
9.	A36855-001	Cover for control box

SCE275 Service Parts

Wire Harnesses

Wire Harnesses are NOT ILLUSTRATED, select by model number and description

A through F series models have single harnesses

G series 60 Hz have single harnesses

G series 50 Hz have split harnesses

Part Number	Description
-------------	-------------

12-2620-01	Main wire harness WC for A - F series
------------	---------------------------------------

12-2619-01	Main wire harness AC for A - F series
------------	---------------------------------------

12-2900-01	Main wire harness AC for G series 60 Hz
------------	---

12-2901-01	Main wire harness WC for G series 60 Hz
------------	---

12-2894-01	24 volt wire harness, AC for G series 50 Hz
------------	---

12-2893-01	Pump wire harness, WC for G series 50 Hz
------------	--

12-2895-01	Pump and fan wire harness, AC for G series 50 Hz
------------	--

12-2892-01	24 volt wire harness, WC for G series 50 Hz
------------	---



SCE275 Service Parts

Wiring Diagram, A series

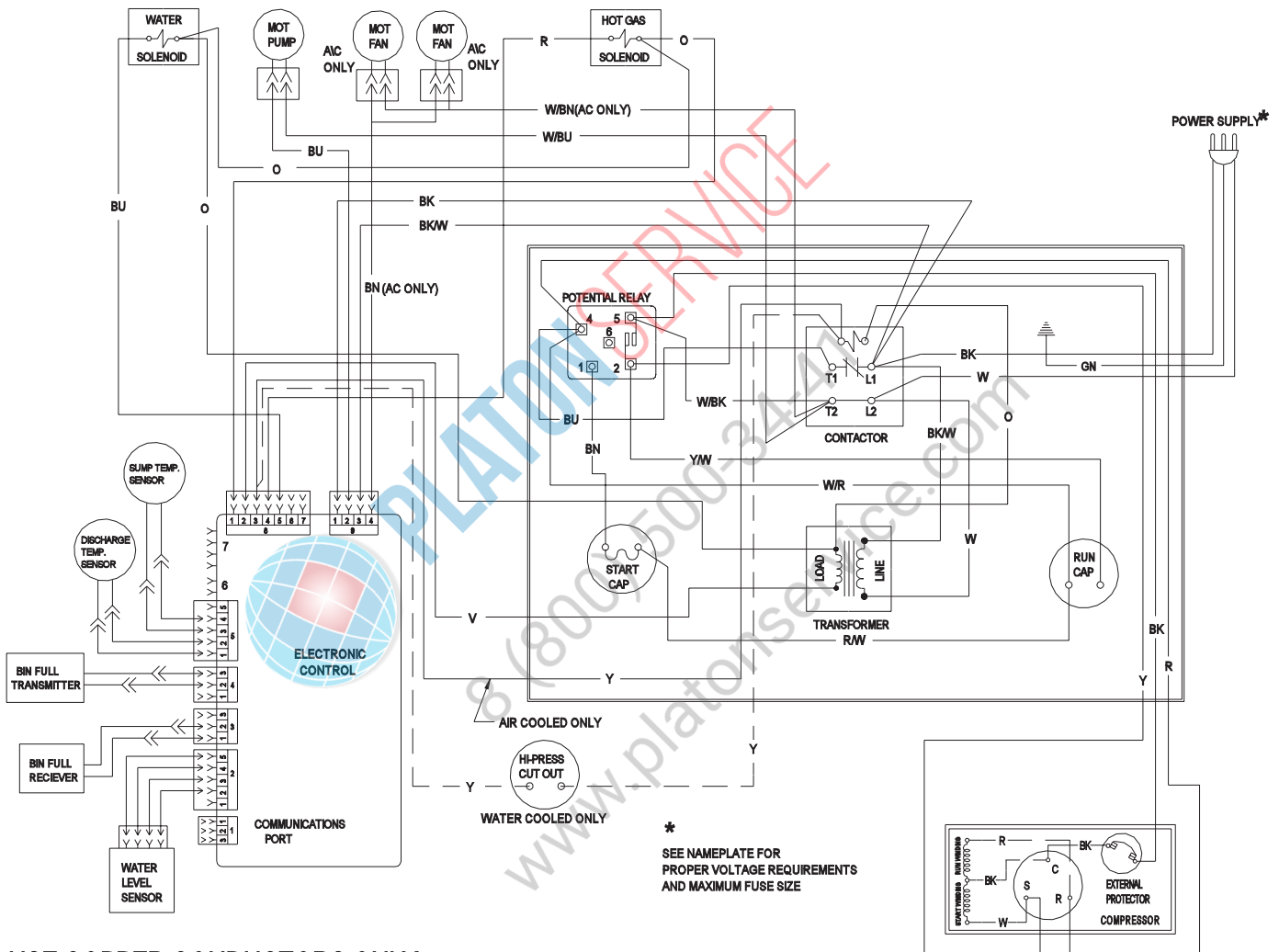

SCE275 Service Parts

Schematic Diagram

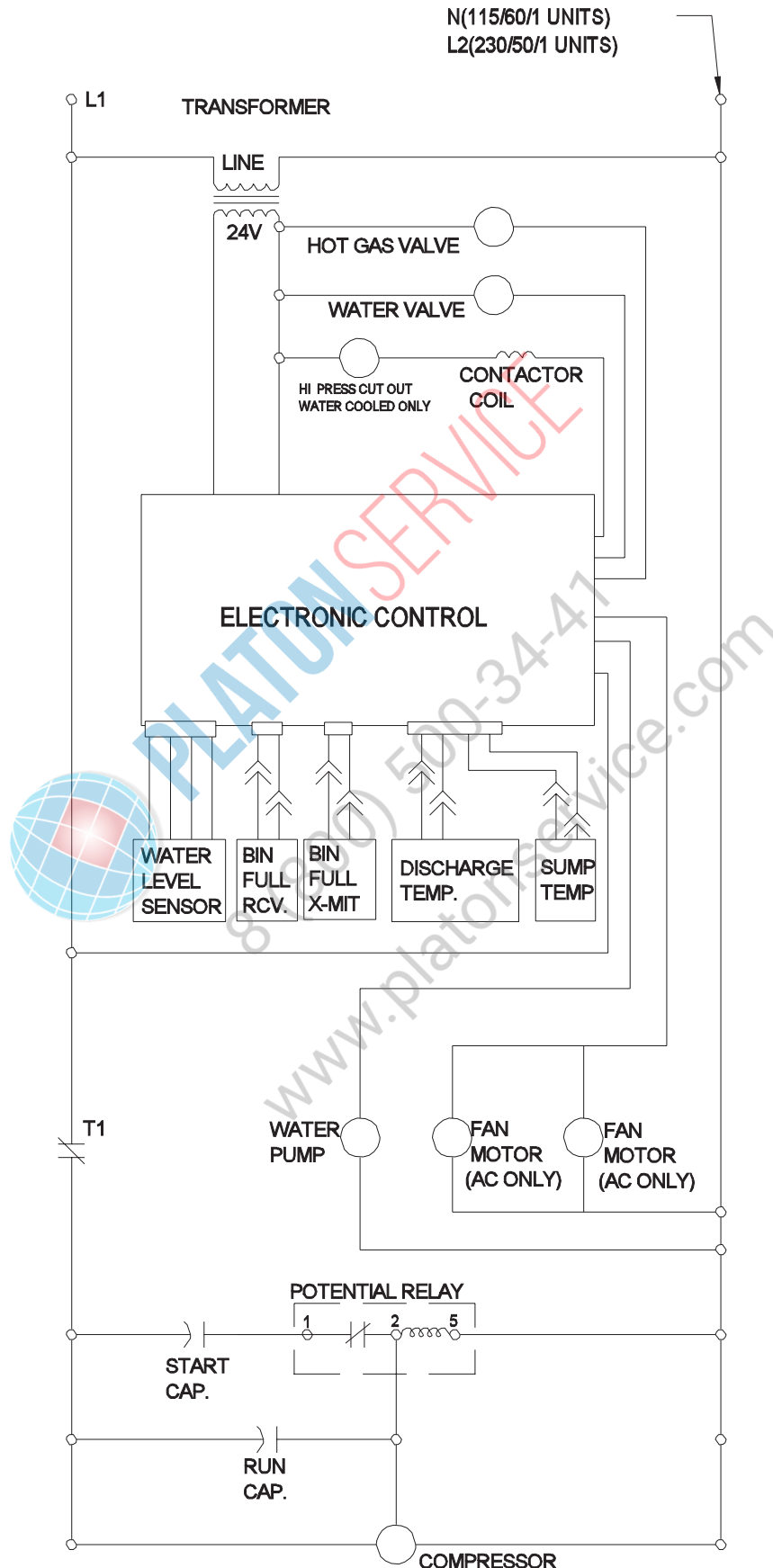

SCE275 Service Parts

60 Hz Wiring Diagram: D, E, F and G Series

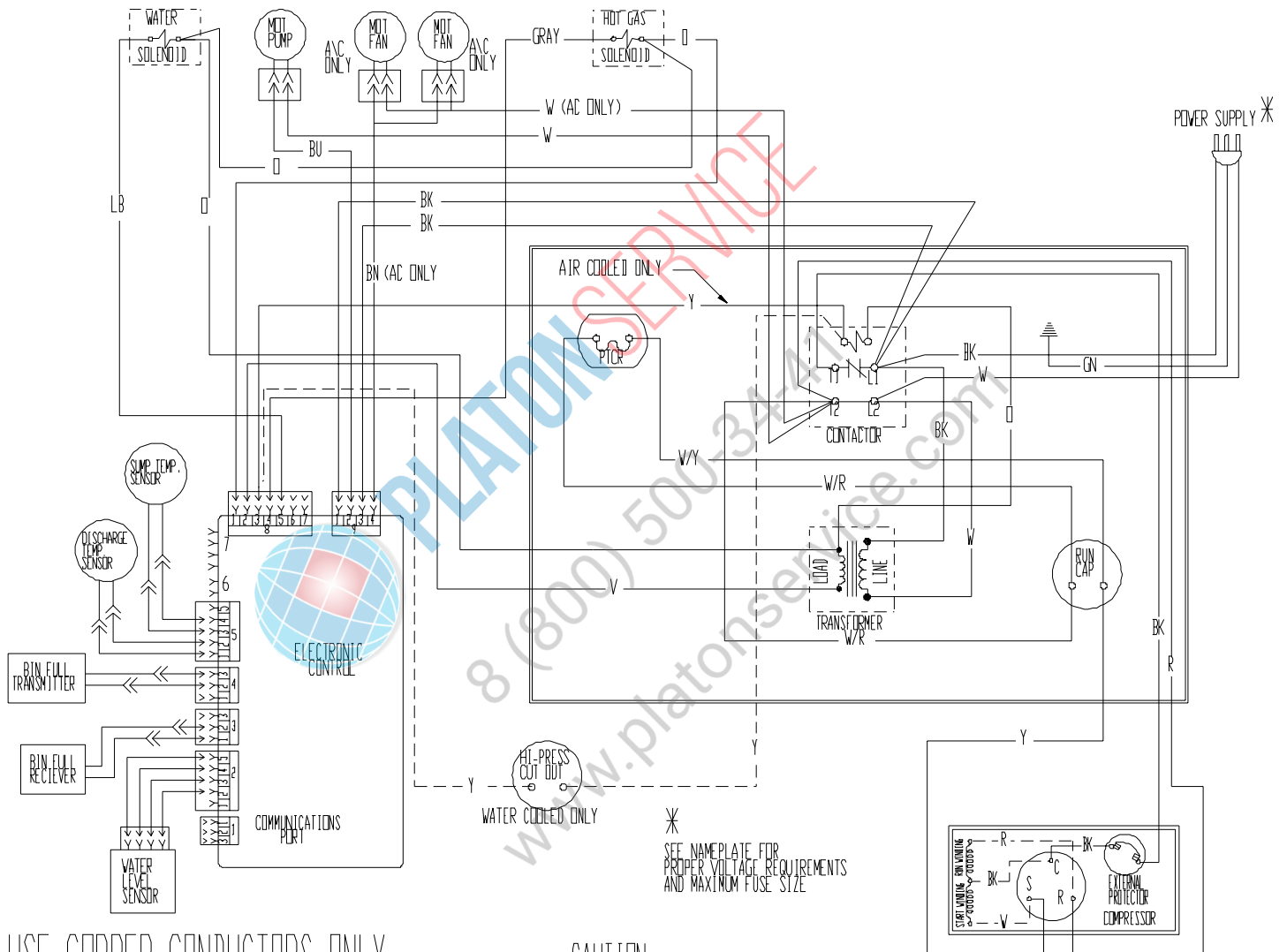

USE COPPER CONDUCTORS ONLY
THIS UNIT MUST BE GROUNDED.

CAUTION:
MORE THAN ONE DISCONNECT MEANS MAY BE REQUIRED TO DISCONNECT ALL POWER TO THIS UNIT.

SCE275 Service Parts

50 Hz Wiring Diagram: - 6E, -6F, and -6G

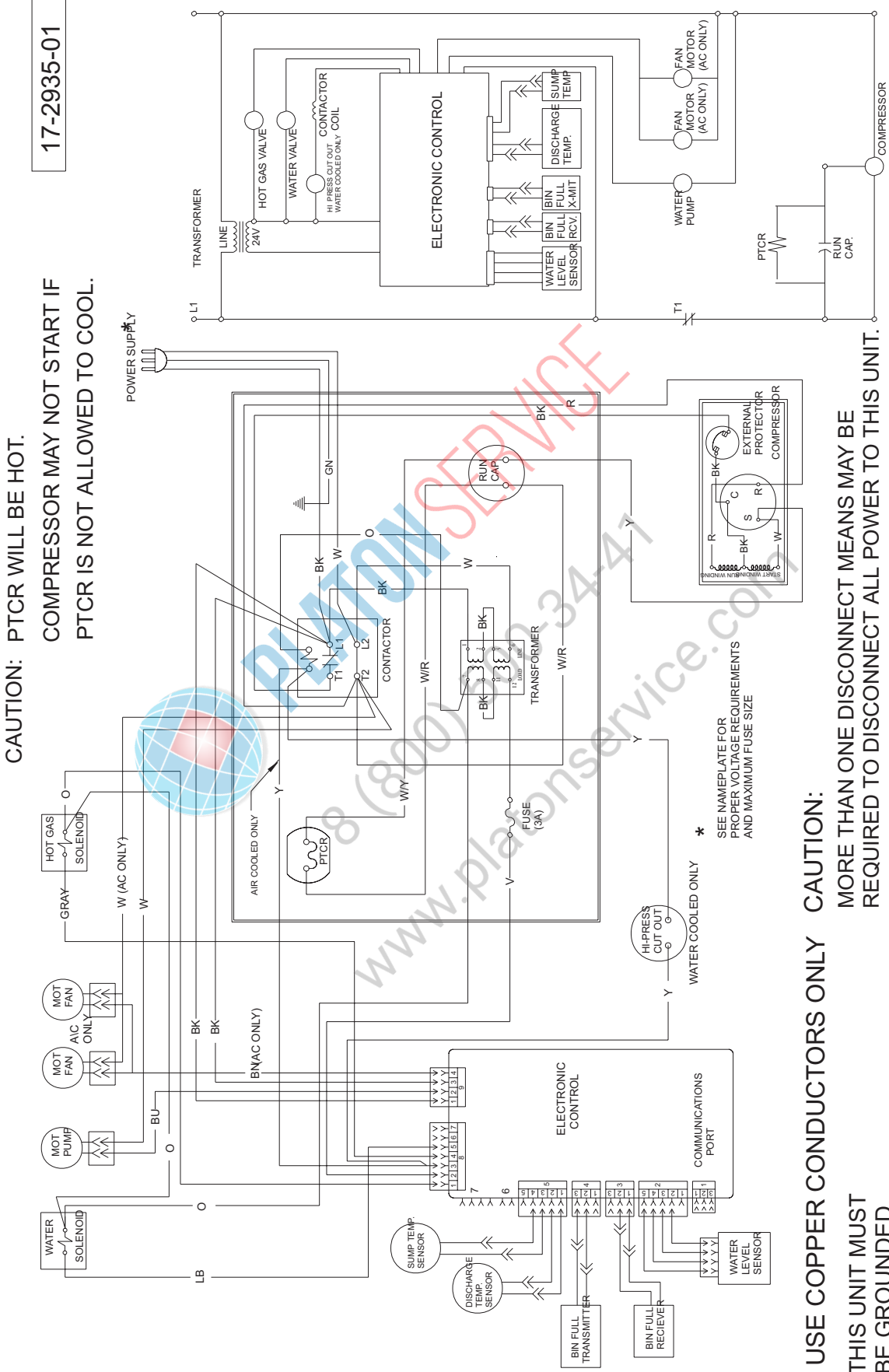

17-2935-01

CAUTION: PTCR WILL BE HOT.
COMPRESSOR MAY NOT START IF PTCR IS NOT ALLOWED TO COOL.

USE COPPER CONDUCTORS ONLY **CAUTION:** MORE THAN ONE DISCONNECT MEANS MAY BE REQUIRED TO DISCONNECT ALL POWER TO THIS UNIT.

THIS UNIT MUST BE GROUNDED.